

6LY2A-STP Series

Configuration	4-stroke, vertical, water-cooled diesel engine	
Maximum output at crankshaft	* 324 kW@3300 rpm	[440 HP@3300 rpm]
	** 315 kW@3300 rpm	[427 HP@3300 rpm]
Displacement	5.813 ltr	[354 cu in]
Bore x stroke	106 mm x 110 mm	[4.17 in x 4.33 in]
Cylinders	6 in line	
Combustion system	Direct injection	
Aspiration	Turbocharged with watercooled turbine housing	
Starting system	Electric starting 12V - 2.5 kW	
Alternator	12V - 80A	
Cooling system	Fresh water cooling by centrifugal fresh water pump and rubber impeller seawater pump	
Lubrication system	Enclosed, forced lubricating system	
Direction of rotation [crankshaft]	Counter clockwise viewed from stern	
Dry weight without gear	535 kg	[1179 lbs]
Environmental	EU: RCD	EMC
Engine mounting	Rubber type flexible mounting	

NOTE:

Fuel condition: Density at 15°C = 0.842 g/cm³; 1HP = 0.7355 kW

* Fuel temperature 25°C at the inlet of the fuel injection pump [ISO 3046-1]

** Fuel temperature 40°C at the inlet of the fuel injection pump [ISO 8665]

Technical data is according to ISO 8665: 2006/3046-1

DIMENSIONS

Rear view

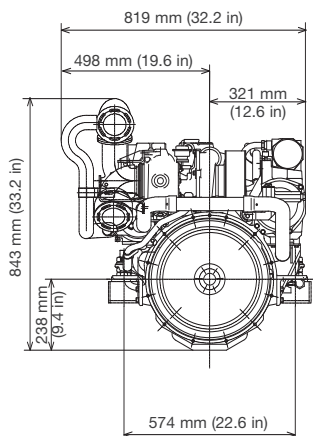

Right side view

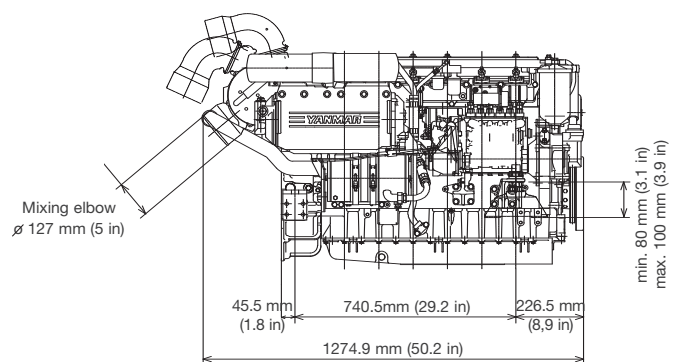

6LY2A-STP with KM2P-1 marine gear

PERFORMANCE CURVES

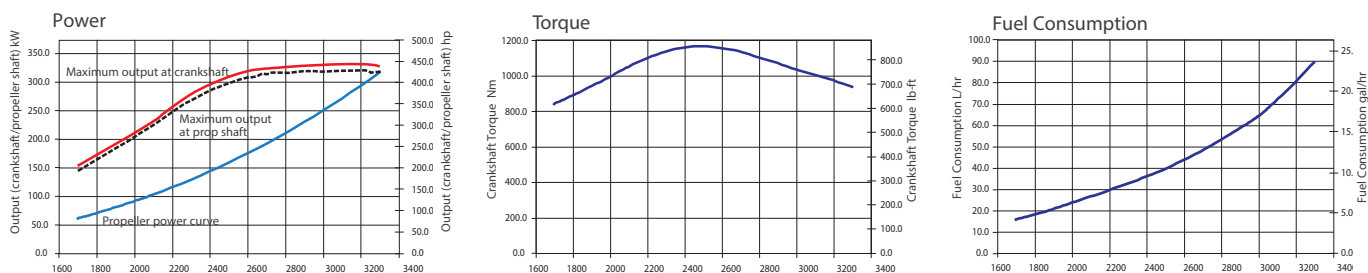

MARINE GEARS / DRIVE

Model	KMH60A		
Type	Hydraulically actuated multi-disc clutch		
Dry weight	58 kg [128 lbs]		
Reduction ratio [fwd/asn]	1.55/1.55	2.04/2.04	2.43/2.43
Propeller speed [fwd/asn]	2000/2000	1520/1520	1276/1276
Direction of rotation [propeller shaft - fwd]	Clockwise & Counterclockwise viewed from stern		
Dry weight engine and gear/drive	588 kg [1296 lbs]		
Length engine and gear/drive	1556 mm [61 in]		

* Other marine gearboxes and configurations available upon request. Contact your local supplier for more information.

Following gears are available: MG5061A reduction ratio: 1.13, 1.54, 1.75, 2.00, 2.47
 MG5061SC (Paralle) reduction ratio: 1.00, 1.15, 1.48 & 1.77
 MG5062V (integral V-drive) reduction ratio: 1.19, 1.53, 1.83 & 2.07
 ZF80A-1 (down angle) reduction ratio: 1.20, 1.41, 1.57 & 1.96

INSTRUMENT PANELS

New B-type Panel

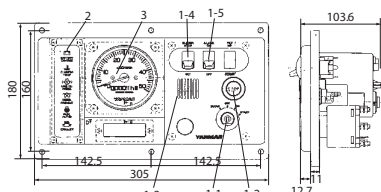

New C-type Panel

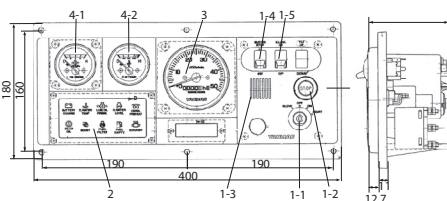

New D-type Panel

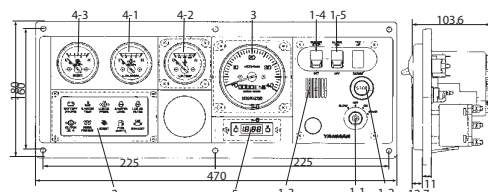

Function	TYPE OF INSTRUMENT PANEL		
	NEW B-TYPE PANEL	NEW C-TYPE PANEL	NEW D-TYPE PANEL
1-Switch unit			
1-1 Key switch [starter switch]	Equipped on panel	Equipped on panel	Equipped on panel
1-2 Engine stop switch	Equipped on panel	Equipped on panel	Equipped on panel
1-3 Alarm buzzer [C.W. Temp., L.O. Pressure]	Equipped on panel	Equipped on panel	Equipped on panel
1-4 Alarm buzzer stop switch	Equipped on panel	Equipped on panel	Equipped on panel
1-5 Illumination switch for meters	Equipped on panel	Equipped on panel	Equipped on panel
2-Alarm lamp unit			
2-1 Battery not charging	Equipped on panel	Equipped on panel	Equipped on panel
2-2 C.W. high temperature	Equipped on panel	Equipped on panel	Equipped on panel
2-3 L.O. low pressure	Equipped on panel	Equipped on panel	Equipped on panel
2-4 Sea water flow	Equipped on panel	Equipped on panel	Equipped on panel
2-5 C.W. level for fresh water tank	Equipped on panel	Equipped on panel	Equipped on panel
2-6 Boost pressure high	Equipped on panel	Equipped on panel	Equipped on panel
3-Tachometer with hour meter	Equipped on panel	Equipped on panel	Equipped on panel
4-Sub meter unit			
4-1 L.O. pressure meter	Not equipped on panel	Equipped on panel	Equipped on panel
4-2 C.W. Temperature meter	Not equipped on panel	Equipped on panel	Equipped on panel
4-3 Boost meter [turbo]	Not equipped on panel	Not equipped on panel	Equipped on panel
5-Quartz clock	Not equipped on panel	Not equipped on panel	Equipped on panel

ACCESORIES

Standard engine package

- Sensor for various panels
- Exhaust/water mixing elbow [L-type]
- Alternator 12V - 80A

Optional accesories

- Flexible mounts
- Fuel water separator
- High-riser/water mixing elbow [instead of L-elbow]
- Sensor for VDO instrument panels
- Analog [new B-type, new C-type and new D-type] instrument panels
- Control heads
- Lub oil evacuation pump
- Dipstick for opposite side

NOTE: All data subject to change without notice. Text and illustrations are not binding.