

4JH110 Common Rail Series

Configuration	4-stroke, vertical, water-cooled diesel engine		
Maximum output at crankshaft	* 80.9 kW@3200 rpm	[110 mhp@3200 rpm]	
Displacement	2.0 ltr	[122 cu in]	
Bore x stroke	84 mm x 90 mm	[3.31 in x 3.54 in]	
Cylinders	4 in line		
Combustion system	Direct injection with common rail system		
Aspiration	Turbocharged with intercooler		
Starting system	Electric starting 12V - 1.4 kW		
Alternator	12V - 125A		
Cooling system	Fresh water cooling by centrifugal water pump and rubber impeller sea water pump		
Lubrication system	Enclosed, forced lubricating system		
Direction of rotation [crankshaft]	Counterclockwise viewed from flywheel side		
Dry weight without gear	224 kg	[494 lbs]	
Environmental	EU: RCD	BSO II	EMC
	US: EPA Tier 3		
Engine mounting	Rubber type flexible mounting		

NOTE:

Fuel condition: Density at 15°C = 0.84 g/cm³: 1 kW = 1.3596 mhp = 1.3410 HP

* Fuel temperature 40°C at the inlet of the fuel injection pump [ISO 8665: 2006]

Technical data is according to ISO 8665: 2006

DIMENSIONS

Rear view

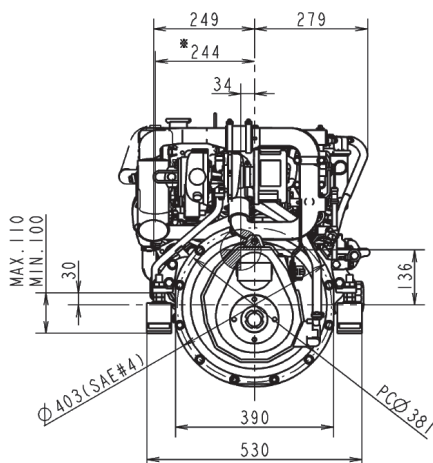

Right side view

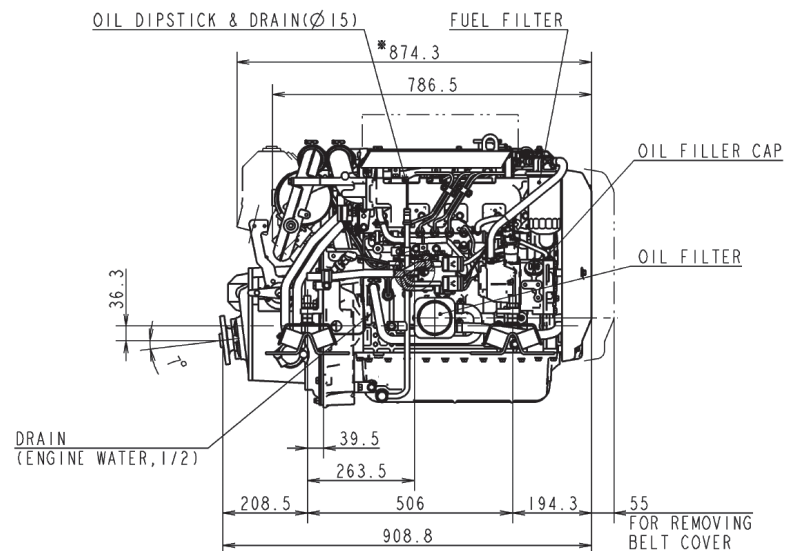

4JH110 with KM4A2 marine gear

PERFORMANCE CURVES

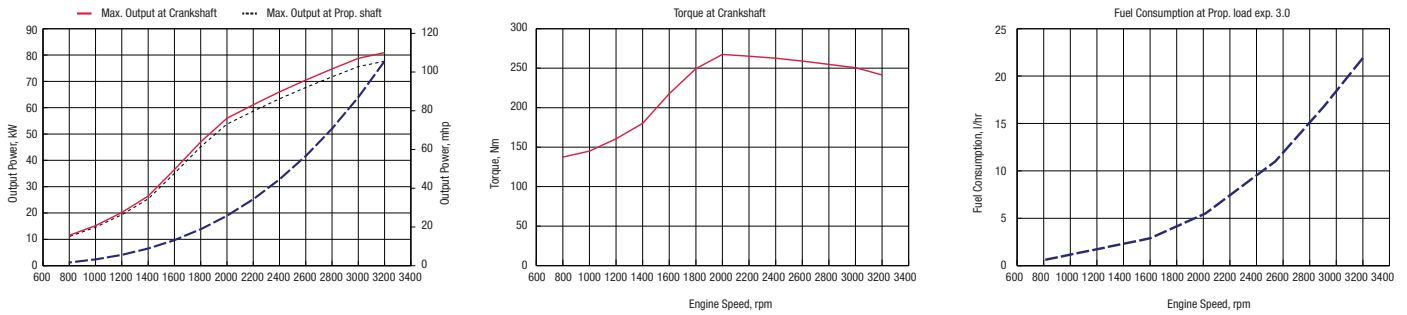

MARINE GEARS

Model	KM4A [down angle: 8°]		ZF25A [down angle: 8°]		KM4A2 [down angle: 7°]			ZF30M	
Type	Hydraulic, multi disk clutch		Hydraulic, multi disk clutch		Mechanical cone clutch			Mechanical multi-disc	
Dry Weight	32 kg [71 lbs]		30 kg [66 lbs]		33 kg [73 lbs]			28 kg [61 lbs]	
Reduction Ratio [fwd/asn]	2.04/2.04	2.45/2.45	1.93/1.93	2.48/2.48	1.47/1.47	2.14 / 2.14	2.63/2.63	2.15/2.64	2.70/2.64
Propeller speed [fwd/asn]	1569/1569	1306/1306	1658/1658	1290/1290	2177/2175	1495/1494	1217/1216	1488/1212	1185/1212
Direction of rotation [propeller shaft - fwd]	Clockwise & counterclockwise viewed from stern		Clockwise & counterclockwise viewed from stern		Clockwise & counterclockwise viewed from stern			Clockwise viewed from stern	
Dry weight - engine & gear	256 kg [564.4 lbs]		254 kg [560 lbs]		257 kg [566.6 lbs]			252 kg [555.6 lbs]	
Length engine and gear/drive	907 mm [35.7 in]		905 mm [35.6 in]		909 mm [35.8 in]			925 mm [36.4 in]	

INSTRUMENT PANELS

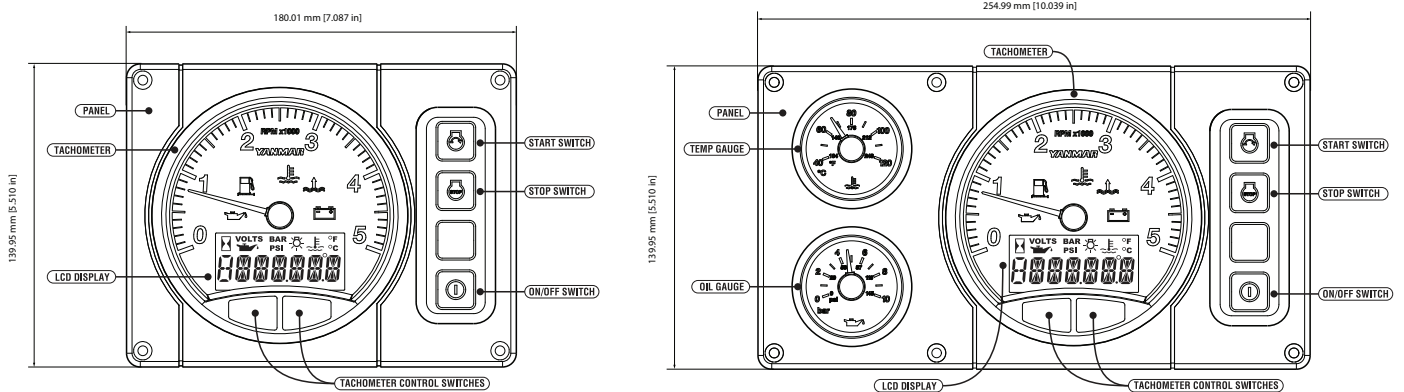

B25 STANDARD

C35 OPTIONAL

ACCESSORIES

Standard Package

- Set of flexible engine mounts
- Exhaust mixing elbow [L-type]
- V-belt safety cover
- Fresh water expansion tank
- Alternator 12V - 120A
- Operation manual
- B25-panel
- Sensors for instrument panel
- Seawaterpump front mounted
- Engine Topcover for protection

Optional

- Second alternator 12V - 125A or 24V - 60A
- High-riser mixing elbow [instead of L-elbow]
- Extension wire harness [3m, 5m, 10m]
- Hot water kit with cocks
- Second station harness
- C35-panel
- Sensor for C35-panel
- Extension saildrive leg [75 mm]
- Propeller cone nut kit SD60
- NMEA 2000 Engine monitory system

NOTE: All data subject to change without notice. Text and illustrations are not binding.