



## WORLD'S FIRST SERIAL PRODUCTION DIESEL OUTBOARD WITH DUAL CRANKSHAFT

The Neander Dtorque Turbo Diesel sets a new benchmark in diesel engineering. Its 804 ccm twin-cylinder aluminum powerhead delivers 50 hp at the propeller shaft. With a remarkable torque output, peaking at 111 Nm at 2,500 rpm, the Dtorque out-performs the best 70 hp fuel injected four-stroke gasoline outboards on the market today. This gives the Dtorque exceptional ability to power heavy loads at low RPM as well as the ability to get on plane quickly, both with a very modest fuel consumption, averaging 12 litres per hour at WOT.

### IS THE DTORQUE RIGHT FOR YOUR BOAT?

At YANMAR, we understand that you should consider many different criteria when investing in an outboard motor. However, when you've got a serious job to do, you need the reliability of a diesel engine. The Dtorque is the ideal choice if you operate or manage:

- work boats
- safety/rescue boats
- fishing boats
- oil and gas, and offshore vessels
- governmental and port authority vessels
- passenger boats
- superyacht tenders

### LOW NOISE AND VIBRATION LEVELS

The Dtorque has a two-cylinder, common rail, turbo-charged diesel engine that uses a unique system of dual counter-rotating crankshafts in an aluminum block. This technology, with its patented 'spaceball' design, helps to reduce vibrations and noise.

Another advantage of these crankshafts is the lack of rotating and operating (steering) torques. This results in less fatigue during the engine's operation.

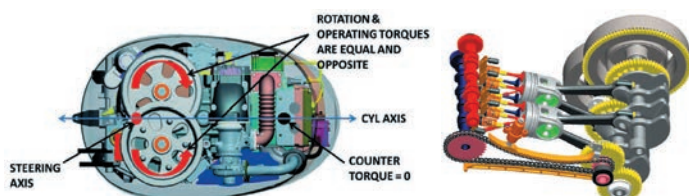

### INCREASED SAFETY



Diesel is less flammable than gasoline, and so the Dtorque is the safer choice for potentially hazardous environments, such as in the oil and gas industry. Superyacht and cruise ship operators, for example, will also benefit from the time and cost savings associated with having fewer fire safety precautions and regulations.

In addition, there is only one type of fuel to manage, which is more widely available in ports all over the world. The Dtorque also exceeds EU RDC Stage II emissions regulations and is SOLAS (MOB) certified, however is not yet EPA compliant.

### HIGH PERFORMANCE AT LOW RPM'S

For a burst of speed, the Dtorque delivers a creditable 50 hp, but its torque is the most important factor in a working environment. The Dtorque's mighty 111Nm at 2,000-3,000 rpm will get your boat quickly on plane and provide all the muscle you need when fully loaded.

### FAVORABLE COST OF OWNERSHIP

As the world's smallest diesel outboard engine with common rail fuel injection, the Dtorque provides impressive performance while maintaining a best-in-class fuel economy. At full throttle, it typically uses under 12 litres of fuel per hour. This equates to around half the average consumption of most 70 hp four-stroke gasoline outboards delivering a similar performance. As a result, the Dtorque requires less refueling stops, maximizing the number of working hours and reducing the overall operating costs. The expected lifespan of the Dtorque is more than 10,000 hours. This is, on average, more than double that of any comparable gasoline outboard engine and allows for extended service intervals.

## ENGINE SPECS

Power	36,8 kW/50 hp at 3.500 - 4.000 min-1
Max. Torque	111 Nm at 2000 - 3000 min-1
Engine Type	4-Stroke turbo diesel
Balance	Dual counter-rotating crankshafts
Swept Volume	804 ccm
Bore x Stroke	80 x 80 mm
No. Cylinders	2 In-Line, twin
Intake	Water cooled turbo charger and charge air cooling
Lubrication	Integrated dry sump - pressure lubricated
Fuel	Diesel
Injection	Bosch common rail direct injection
Starting	Electric
Alternator	Standard 12 V /300 W
Cooling	NEANDER Active Thermo-Management System (ATMS)
Exhaust	Integrated underwater thru-hub propeller
Steering	Tiller / remote control, optional
Suspension	Silent-block-controlled compression and traction
Trim	Power trim
Shift	Mechanical - dog-clutch gearing
Transmission	Ratio 13/27 (2.07:1)
Available Shaft	Versions 20" (L) and 25" (XL)
Standard Propeller Type	3-blade with built -in damper
Weight	Basic version 175 kg (dry)

Technical data is subject to change

## CERTIFICATION

The Dtorque exceeds EU RDC Stage II emissions regulations and is SOLAS (MOB) certified.



## TECHNICAL DATA

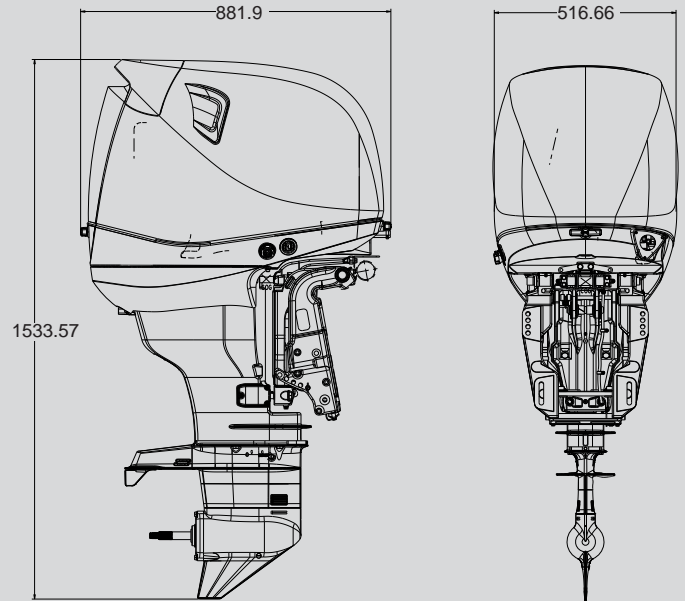
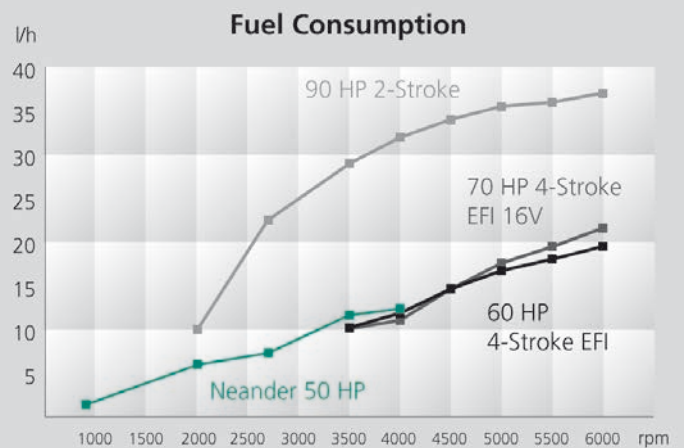
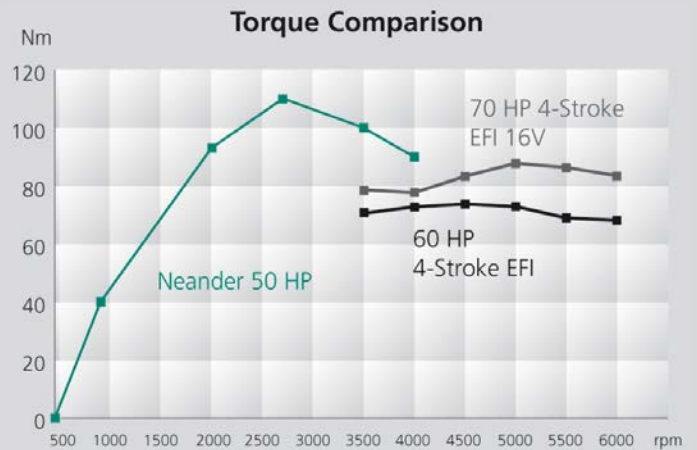

### EXCLUSIVE WORLDWIDE DISTRIBUTION PARTNER

YANMAR is pleased to offer you direct access to our technical excellence in marine diesel engineering and a well-established distribution network for Dtorque. This covers over 130 countries around the world with strategically located dealer service centers.

### A LEAP FORWARD IN OUTBOARD ENGINEERING

Neander Shark GmbH is a whole subsidiary of Neander Motors AG. With an international project team of excellent engineers and developers they implemented their unique twin crankshaft concept in the maritime world, resulting in the production of world's first turbo diesel outboard engine under 100 hp.